

Swivel Joints / Chicksan to Rent!

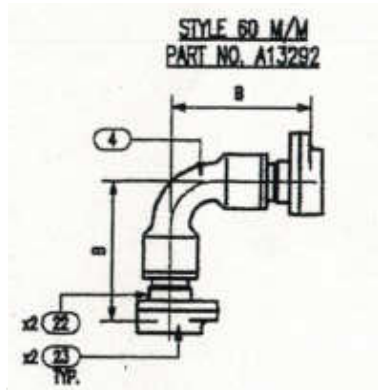

Size	Description	HPS Rental Order No.
2"	1502-2"M – 1502-2" M	400.0248

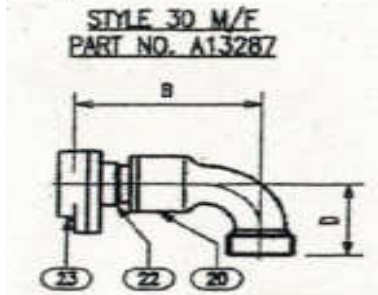

2"	1502-3"M – 1502-2" F	400.0247
----	----------------------	-----------------

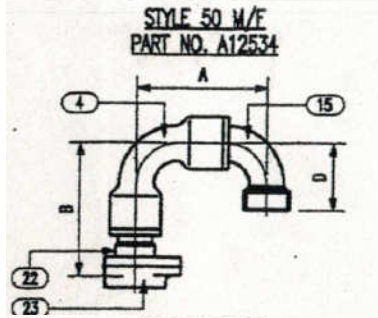

2"	1502-2"M – 1502-2" F	400.0245
2"	1502-3"M – 1502-2" F	400.0246
3"	1502-3"M – 1502-3" F	400.0240

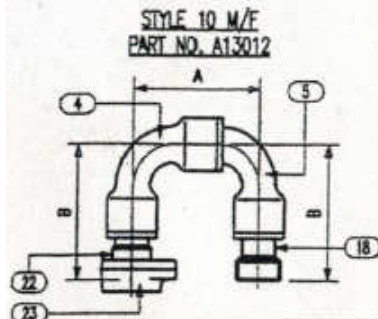

2"	1502-2"M – 1502-2" F	400.0242
----	----------------------	-----------------

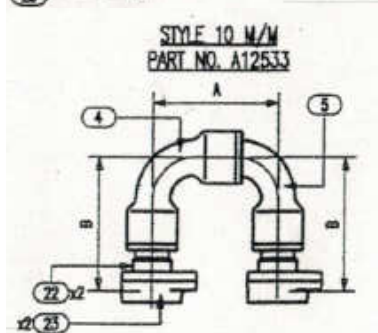

2"	1502-2"M – 1502-2" M	400.0243
2"	1502-3"M – 1502-2" M	400.0244

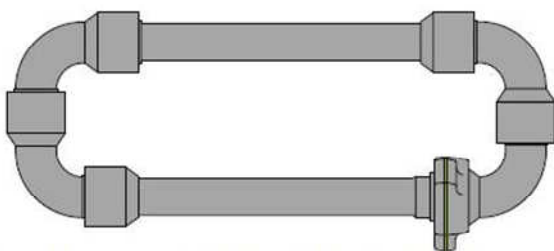

2"	1502-2"M – 1502-2" F / 8 ft	400.024
2"	1502-2"M – 1502-2" F / 10ft	400.0241